

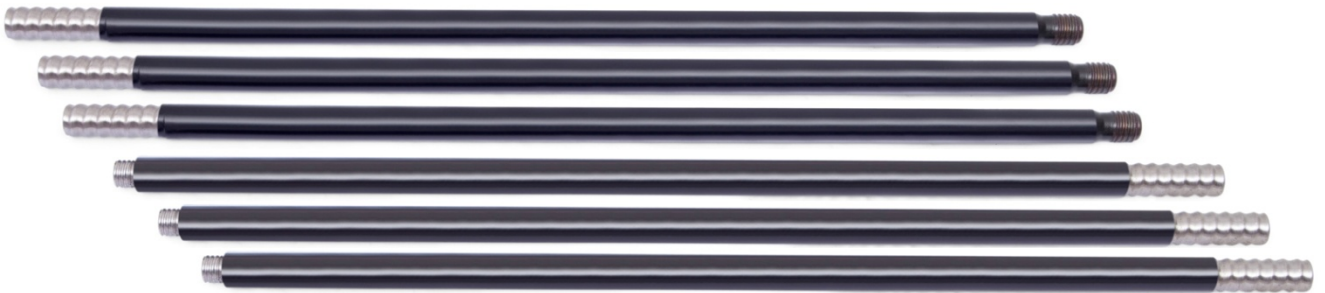



Taphole Drill Rod For Blast Furnaces



Single-Lug (Double-Lug) Threaded Drill Rod

| Description | Length | | Diameter | | Part No. |
|---|--------|-------|----------|--------|--------------|
| | mm | in | mm | in | |
|  | 1830 | 6' | 32 | 1 1/4" | MT32-18 H25L |
| | 2435 | 8' | 32 | 1 1/4" | MT32-24 H25L |
| | 3050 | 10' | 32 | 1 1/4" | MT32-30 H25L |
| | 3660 | 12' | 32 | 1 1/4" | MT32-36 H25L |
| | 3830 | 12'6" | 32 | 1 1/4" | MT32-38 H25L |
| | 4300 | 14'1" | 32 | 1 1/4" | MT32-43 H25L |
|  | 1830 | 6' | 38 | 1 1/2" | MT38-18 D30L |
| | 2435 | 8' | 38 | 1 1/2" | MT38-24 D30L |
| | 3050 | 10' | 38 | 1 1/2" | MT38-30 D30L |
| | 3660 | 12' | 38 | 1 1/2" | MT38-36 D30L |
| | 3830 | 12'6" | 38 | 1 1/2" | MT38-38D30L |
| | 4300 | 14'1" | 38 | 1 1/2" | MT38-43 D30L |



Single-Lug(Double-Lug) Welding Drill Rod

| Description | Length | | Diameter | | Part No. |
|---|--------|-------|----------|--------|----------|
| | mm | in | mm | in | |
|  | 3500 | 11'6" | 32 | 1 1/4" | MW32-35L |
| | 4270 | 14' | 32 | 1 1/4" | MW32-42L |
| | 4420 | 14'6" | 32 | 1 1/4" | MW32-44L |
| | 5000 | 16'4" | 32 | 1 1/4" | MW32-50L |
| | 5400 | 17'7" | 32 | 1 1/4" | MW32-54L |
| | 6000 | 19'8" | 32 | 1 1/4" | MW32-60L |
|  | 3500 | 11'6" | 38 | 1 1/2" | MW38-35L |
| | 4270 | 14' | 38 | 1 1/2" | MW38-42L |
| | 4420 | 14'6" | 38 | 1 1/2" | MW38-44L |
| | 5000 | 16'4" | 38 | 1 1/2" | MW38-50L |
| | 5400 | 17'7" | 38 | 1 1/2" | MW38-54L |
| | 6000 | 19'8" | 38 | 1 1/2" | MW38-60L |

Extension Drill Rod

| Description | Length | | Diameter | | Part No. |
|--|--------|-------|----------|--------|--------------------------------------|
| | mm | in | mm | in | |
|  | 1830 | 6' | 32 | 1 1/4" | ME32-18R32/H25 |
| | 2435 | 8' | 32 | 1 1/4" | ME32-24R32/H25 |
| | 3050 | 10' | 32 | 1 1/4" | ME32-30R32/H25 |
| | 3660 | 12' | 32 | 1 1/4" | ME32-36R32/H25 |
| | 3830 | 12'6" | 32 | 1 1/4" | ME32-38R32/H25 |
| | 4300 | 14'1" | 32 | 1 1/4" | ME32-43R32/H25 |
| | 1830 | 6' | 38 | 1 1/2" | ME38-18R38/R38 (ME38-18R38 / D30) |
| | 2435 | 8' | 38 | 1 1/2" | ME38-24R38/R38 (ME38-24R38 / D30) |
| | 3050 | 10' | 38 | 1 1/2" | ME38-30R38/R38 (ME38-30R38 / D30) |
| | 3660 | 12' | 38 | 1 1/2" | ME38-36R38/R38 (ME38-36R38 / D30) |
| | 3830 | 12'6" | 38 | 1 1/2" | ME38-38R38/R38 (ME38-38R38 / D30) |
| | 4300 | 14'1" | 38 | 1 1/2" | ME38-43R38/R38 (ME38-43R38 / D30) |

Semi-finished Materials

| Description | Length | | Part No. |
|---|--------|--------|---------------------|
| | mm | in | |
|  | 32 | 1 1/4" | Hollow Drill Steel |
| | 38 | 1 1/2" | |
|  | 32 | 1 1/4" | Seamless Steel Pipe |
| | 38 | 1 1/2" | |

Coupling Sleeve

| Description | Length | | Diameter | | Thread | Part No. |
|---|--------|----------|----------|----------|--------|------------|
| | mm | in | mm | in | | |
|  | 150 | 5 29/32" | 44 | 1 47/64" | R32 | MC4415-R32 |
| | 170 | 6 3/4" | 55 | 2 5/32" | R35 | MC5517-R35 |
| | 170 | 6 3/4" | 55 | 2 5/32" | R38 | MC5517-R38 |

Pneumatic Break Steel

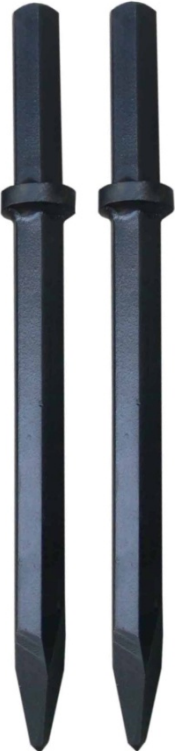
| Point | Shank Size | | Length | | Part No. | Weight |
|--|--------------------|--------------------------------|--------|-------------|-------------|--------|
| | mm | in | mm | in | | Kg |
|  | 22x82.5 22x108 | 7/8" x 31/4" 7/8" x 41/4" | 355 | 14" | MP2201-355 | 1.55 |
| | | | 457 | 18" | MP2201-457 | 1.9 |
| | | | 609 | 24" | MP2201-609 | 2.41 |
| | | | 914 | 36" | MP2201-914 | 3.43 |
| | 25x108 | 1" x 41/4" | 355 | 14" | MP2501-355 | 1.99 |
| | | | 457 | 18" | MP2501-457 | 2.42 |
| | | | 609 | 24" | MP2501-609 | 3.08 |
| | | | 914 | 36" | MP2501-914 | 4.47 |
| | | | 1219 | 48" | MP2501-1219 | 5.7 |
| | | | 1524 | 60" | MP2501-1524 | 7.01 |
| | | | 1828 | 72" | MP2501-1828 | 8.32 |
| | 28x152 | 1 1/8" x 6" | 355 | 14" | MP2801-355 | 2.72 |
| | | | 457 | 18" | MP2801-457 | 3.24 |
| | | | 609 | 24" | MP2801-609 | 4.05 |
| | | | 914 | 36" | MP2801-914 | 5.68 |
| | | | 1219 | 48" | MP2801-1219 | 7.3 |
| | | | 1524 | 60" | MP2801-1524 | 8.93 |
| | | | 1828 | 72" | MP2801-1828 | 10.55 |
| | 32x152 (32x160) | 1 1/4" x 6" 1 1/4" x 6 1/3" | 355 | 14" | MP3201-355 | 3.93 |
| | | | 457 | 18" | MP3201-457 | 4.08 |
| | | | 609 | 24" | MP3201-609 | 6.43 |
| | | | 914 | 36" | MP3201-914 | 7.08 |
| | | | 1219 | 48" | MP3201-1219 | 9.1 |
| | | | 1524 | 60" | MP3201-1524 | 11.11 |
| 1828 | | | 72" | MP3201-1828 | 13.12 | |

| Chisel | Shank Size | | Length | | Part No. | Weight | |
|--|------------------|------------------------------|--------|------|-------------|-------------|-------|
| | mm | in | mm | in | | Kg | |
|  | 22x82 22x108 | 7/8" x 31/4" 7/8" x 41/4" | 355 | 14" | MP2202-355 | 1.55 | |
| | | | 457 | 18" | MP2202-457 | 1.9 | |
| | | | 609 | 24" | MP2202-609 | 2.41 | |
| | | | 914 | 36" | MP2202-914 | 3.43 | |
| | 25x108 | 1" x 41/4" | 355 | 14" | MP2502-355 | 1.99 | |
| | | | 457 | 18" | MP2502-457 | 2.42 | |
| | | | 609 | 24" | MP2502-609 | 3.08 | |
| | | | 914 | 36" | MP2502-914 | 4.4 | |
| | | | 1219 | 48" | MP2502-1219 | 5.7 | |
| | | | 1524 | 60" | MP2502-1524 | 7.01 | |
| | 28x152 28x160 | 11/8" x 6" 11/8" x 61/3" | 1828 | 72" | MP2502-1828 | 8.32 | |
| | | | 355 | 14" | MP2802-355 | 2.72 | |
| | | | 457 | 18" | MP2802-457 | 3.24 | |
| | | | 609 | 24" | MP2802-609 | 4.06 | |
| | | | 914 | 36" | MP2802-914 | 5.68 | |
| | | | 1219 | 48" | MP2802-1219 | 7.3 | |
| | 32x152 32x160 | 11/4" x 6" 11/4" x 61/3" | 1524 | 60" | MP2802-1524 | 8.93 | |
| | | | 1828 | 72" | MP2802-1828 | 10.55 | |
| | | | 355 | 14" | MP3202-355 | 3.39 | |
| | | | 457 | 18" | MP3202-457 | 4.08 | |
| | | | 609 | 24" | MP3202-609 | 6.43 | |
| | | | 914 | 36" | MP3202-914 | 7.08 | |
| | | | | 1219 | 48" | MP3202-1219 | 9.1 |
| | | | | 1524 | 60" | MP3202-1524 | 11.11 |
| | | | 1828 | 72" | MP3202-1828 | 13.12 | |



Welding Button Bit Part No. Rules

M WB 38 20 -7 A

| | | |
|-----------|---------------------------|-------------|
| M | MAXDRILL | |
| WB | Welding Button Bit | |
| 38 | Diameter | 38mm-70mm |
| 20 | d | 16.5mm-21mm |
| 7 | Carbide Number | 6-9 |
| A | A | L=18 |
| | B | L=10 |

Taphole Drill Rod Part No. Rules

M T 32 -18 R32/H25L

| | | |
|------------|-----------------|---------------------|
| M | MAXDRILL | |
| T | T | Threaded Drill Rod |
| | W | Welding Drill Rod |
| | E | Extension Drill Rod |
| | C | Coupling Sleeve |
| 32 | Diameter | |
| 18 | Length | 1830mm-4300mm |
| R32 | Thread | |
| H25 | | |
| L | Lug | |

Pneumatic Break Steel Part No. Rules

M P 22 01 -355

| | | |
|------------|------------------------------|--|
| M | MAXDRILL | |
| P | Pneumatic Break Steel | |
| 22 | Shank Size | Hex.22mm, Hex.25mm, Hex.28mm, Hex.32mm |
| 01 | 01 | Head type point |
| | 02 | Head type chisel |
| 355 | Length | 355mm-1828mm |